



ARCEUS

A blue graphic element consisting of a horizontal line that turns downwards at a right angle, ending in a small circle, positioned below the word 'ARCEUS'.

**ARCEUS  
ELECTRIC COMBI BOILER**

**ARCEUS EC  
6-9-12-15-18-24-27 kW MT / CH / ST**

**SERVICE MANUAL**



## TABLE OF CONTENTS

<b>GENERAL WARNINGS .....</b>	<b>4</b>
<b>1. Device Control, Button Functions and Service Menus .....</b>	<b>5</b>
1.1. Control Panel .....	5
1.2. Button Functions .....	5
1.3. Introduction to Parameter, Information and Error History Menus .....	6
1.4. Cable Diagrams by Capacities .....	9
1.5. Detailed View and List of Components .....	13
1.6. Power Supply Connection Requirements .....	14
<b>2. Error Codes and Solutions .....</b>	<b>15</b>
2.1. Solutions for Coded Errors .....	15
2.2. Solutions for Errors not being Displayed .....	17
<b>3. ASSEMBLYING/DISASSEMBLYING PROCEDURES OF PARTS .....</b>	<b>21</b>
3.1. Front Panel .....	21
3.2. Side Panels .....	21
3.3. Contactor .....	21
3.4. Circuit Breaker .....	22
3.5. Neutral Busbar .....	22
3.6. Supply-Return Manifold .....	22
3.7. Pump .....	22
3.8. Air Purger .....	22
3.9. Limit Thermostat .....	22
3.10. Mainboard .....	23
3.11. Relay Boards .....	26
3.12. Expansion Tank .....	26
3.13. Inlet Duct .....	26
3.14. Return Duct .....	26
3.15. 3 Bar Safety Valve .....	26
3.16. Drainage Tap .....	26
3.17. Motorised Valve .....	26
3.18. Submersion Type NTC .....	27
3.19. Plate Exchanger .....	27
3.20. Main Exchanger Tank .....	27
3.21. Switch Cover .....	27
3.22. Pressure Sensor .....	27
3.23. Resistor Replacement .....	28
3.24. Controller and Sensor Connections .....	28

## **4.PART DEFINITIONS AND ERROR TYPES ..... 30**

4.1. Heating Resistor.....	30
4.2. Main Exchanger Tank .....	32
4.3. Circuit Breaker .....	33
4.4. Neutral Busbar .....	34
4.5. Mainboard .....	34
4.6. Relay Board .....	35
4.7. Pump.....	37
4.8. Neutral and Ground Terminals .....	38
4.9. Motorised Valve .....	38
4.10. Plate Exchanger.....	40
4.11. Contactor.....	41
4.12. Expansion Tank .....	43
4.13. Limit Thermostat .....	44
4.14. Surface Type NTC .....	45
4.15. Submersion Type NTC.....	46
4.16. Flow Sensor .....	47
4.17. Air Purger .....	48
4.18. Water Pressure Sensor.....	49
4.19. Flow Turbine .....	50
4.20. 3 Bar Safety Valve .....	51

## **GENERAL WARNINGS**

- Circuit Breaker poles, contactor main and auxiliary contacts and coil terminals, motorised valve connector terminals, resistance and relay contact terminals, pump connector terminals, overheat thermostat and motherboard should never be contacted with bare hands during interventions to the device.
- If water leaks are observed in the cabinet during the intervention to the device, the energy supply should be cut off immediately and supplied in a controlled manner after the wet areas are dried.
- Sharp points of the device such as bending points of panels should not be touched with bare hands.
- When intervening, points of the device that may be extremely hot, such as the inlet duct, main exchanger tank body, plate exchanger, should be treated in a controlled manner and interventions that may cause injuries due to sudden reflexive movements should be avoided.
- In the operations performed for re-installation or transportation of the device, the items of "E.C.A. Electric Combi Boiler Installation and Commissioning Checklist" should be taken as a basis and checked one by one.

# 1. Device Control, Button Functions and Service Menus

## 1.1. Control Panel

The control panel that provides control of the device consists of 5 different buttons. The layout of the buttons is as follows:

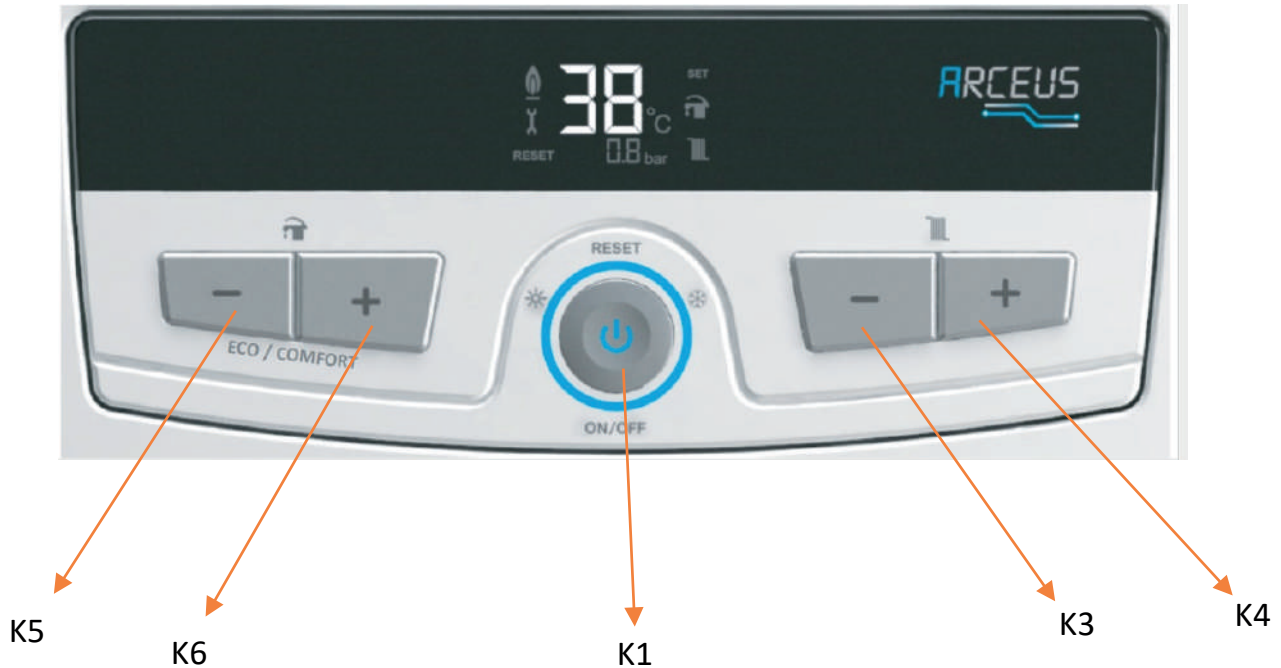

## 1.2. Button Functions

Key Number	Key Name	Function
K1	Mode	<ul style="list-style-type: none"> <li>- The short press switches between STANDBY MODE, SUMMER MODE and WINTER MODE.</li> <li>- Resets error</li> <li>-Allows skipping test mode</li> <li>- Allows skipping AP function</li> <li>- Directs to the service menu when pressed for 5 seconds</li> <li>- Provides access to the selected sub-menu in the service menu</li> <li>- Saves the changes and exits when pressed for 5 seconds in the parameters menu</li> <li>- Exits the error history menu when pressed for 5 seconds</li> </ul>
K3	CH Minus	<ul style="list-style-type: none"> <li>- Decreases central heating set temperature</li> <li>- Decreases the password value when entering the parameters menu</li> <li>- Decreases the parameter value</li> <li>- Displays information value</li> <li>- Displays error history value</li> </ul>
K4	CH Plus	<ul style="list-style-type: none"> <li>- Increases central heating set temperature</li> <li>- Increases the password value when entering the parameters menu</li> <li>- Increases the parameter value</li> <li>- Displays information value</li> <li>- Displays error history value</li> </ul>
K5	DHW Minus	<ul style="list-style-type: none"> <li>- Decreases the domestic water set temperature</li> <li>- Allows selection between parameter, information, error history and cleaning error history menus</li> <li>- Confirms password when entering the parameters menu</li> <li>- Decreases the parameter number</li> <li>- Displays information number</li> <li>- Decreases the error history number</li> </ul>
K6	DHW Plus	<ul style="list-style-type: none"> <li>- Increases the domestic water set temperature</li> <li>- Allows selection between parameter, information error history and cleaning error history menus</li> <li>- Confirms password when entering the parameter menu</li> <li>- Increases the parameter number</li> <li>- Displays information number</li> <li>- Increases the error history number</li> </ul>
K5&K6	DHW- & DHW+	Pressing and holding for 5 seconds switches between Eco and Comfort modes
K3&K4	CH- & CH+	Single Resistor Test Mode
K3&K5	CH- & DHW-	Provides access into full capacity test mode when pressed for 5 seconds.

## 1.3. Introduction to Parameter, Information and Error History Menus

The service menu is accessed if K1 key is pressed for 5 seconds. The sub-menu desired to be entered is opened with K1 key by switching between the symbols displayed on the screen with the K5 and K6 keys.

Displayed Symbol	Menu Description
tS	Parameters Menu
In	Information Menu
Hi	Error History Menu

### 1.3.1. Parameters Menu

When "tS" symbol appears on the screen after pressing K1 for 5 seconds, press K1 once again and "00" is displayed on the screen. The displayed message is the password screen required to access the service menu. When this screen appears, change the password by using K3 and K4 and confirm the password with K5 or K6.

For restricted menu access, the required password should be entered as 03 and K5 or K6 should be pressed. With this password, only P00, P03, P05, P23, P24, P30, P33 parameters can be accessed.

In order to access the F22 parameter, which must be changed for the boiler capacity selection, the password should be 15. With this password, only the capacity selection parameter can be accessed.

Parameter numbers are displayed on the screen after the password is entered. You can navigate through the parameter numbers with the K5 and K6 buttons, and increase or decrease the parameter number you want to change or read by entering it with K3 or K4.

While in the parameters menu, press K1 once to return to the menu selection screen. You can return to the main screen by pressing and holding K1 for 5 seconds. If no button is pressed for 60 seconds, the normal operation screen will be returned.

#### 1.3.1.1. Table of Parameters

Parameter	Parameter Name Definitions of Parameter Values	Setting Range	Factory Setting P00				
			1	2	3	4	5
<b>P00</b>	Domestic water configuration * 1 =Instantaneous heater 2 =Instantaneous heater+Solar energy 3 = Storage tank 4 = Solar energy storage tank 5 =Central heating only	1-5	1	2	3	4	5
<b>P03</b>	Type of heating system 0=Radiator heating 1=Ground heating When parameter P03 is set to 1, P02 is limited to 45°C. When parameter P03 is set to 1, P02 is limited to 80°C.	0-1	0	0	0	0	0
<b>P05</b>	Type of domestic water request 0: Pakkens Brass Flow Sensor +CEME-GTE Sensor 1:- 2: Emas Flow Sensor + Bitron Pressure Switch 3: Pakkens C Flow Sensor +CEME-GTE Sensor 4:-	0-4	0	0	0	0	0
<b>P23</b>	AFCT waiting time for central heating request (min.)	0-10	3	3	3	3	3

<b>P24</b>	Pump overrun time after central heating request (sec)	0-99	60	60	60	60	60
<b>P30</b>	K factor for outdoor temperature sensor compensation	0-30	0	0	0	0	0
<b>P33</b>	Domestic water shut off temperature configuration 0: Stop at 71°C 1: Domestic water set value + FP04	0-1	1	1	1	1	-
<b>F22</b>	Boiler Capacity 6 = 6KW 9=9KW 12 = 12KW 15 = 15KW 18 = 18KW 24 = 24KW 27 = 27KW	6,9,12,15, 18,24,27	24	24	24	24	24

### 1.3.2. Information Menu

After pressing and holding K1 for 5 seconds, proceed with K5 and K6 to display "In" symbol on the screen. When you see this symbol, you can enter the information menu by pressing K1 again. After entering the menu, you can navigate between the information numbers with K5 and K6 and display the value in the information number you want by pressing K3 or K4 once. While displaying the value in the information menu, you can change to the information number by pressing K1 once. Pressing K1 once while on the information number selection screen provides access to the service menu selection screen. If no button is pressed for 60 seconds, the normal operation screen will be returned.

The information menu is where you can access some of the instant measurement and operating information of the device. The values you can access from the information menu are included in the following table:

Information Number	Description
i00	Instant central heating inlet temperature (°C)
i01	Instant central heating return temperature (°C)
i02	Instant domestic water temperature (Instantaneous/Tank/Above tank) (°C)
i03	Instant domestic water temperature (Below tank) (°C)
i04	Solar panel temperature (°C)
i05	Instant flow (L/minute x 10)
i06	Instant outdoor air temperature (°C)
i07	Calculated central heating set temperature (°C)
i08	Number of active relays
i09	Software version

### 1.3.3. Error History Menu

After pressing and holding K1 for 5 seconds, proceed with K5 and K6 to display "Hi" symbol on the screen. When you see this symbol, you can enter the error history menu by pressing K1 again. After entering the menu, you can display the last 8 codes by switching between the last error codes with K3 and K4. Pressing K1 once while the error codes are displayed on the screen directs to the service menu selection screen. You can return to the main screen by pressing and holding K1 for 5 seconds. If no button is pressed for 60 seconds, the normal operation screen will be returned.

### 1.3.4. Annual Maintenance Counter Reset

While the "tS" symbol is displayed on the screen, the password selection menu is accessed by pressing K1. Here, the value of "11" is reached by using K3 and K4 and the value is selected with K1 or K3. The value "P34" will blink on the screen. K4 allows you to enter and "rE" symbol is displayed on the screen. The annual maintenance counter is reset by pressing K1 while the "rE" symbol is displayed on the screen.

### 1.3.5- Single Resistor Test Mode

Test mode is activated by pressing K3 and K4 buttons together for 5 seconds. Test mode simulates a CH heat demand and it activates a single resistor.

Test mode is terminated if K1 button is pressed or Test mode timeout period exceeds.

K4 button -> Changes active relay (Resistor 1 through resistance 9)

K3 button -> Changes active relay (Resistor 9 through resistance 1)

Timeout period is 15 minutes for test mode.

### 1.3.6- Full Capacity Test Mode

Тоа е режимот што му овозможува на уредот да работи со полн капацитет и да контролира дали се активирани сите отпори. Може да се работи најмногу 3 пати откако уредот ќе се вклучи. Буквите „Ft“ се појавуваат за време на овој режим на тестирање.



# 1.4. Cable Diagrams by Capacities

## 1.4.1. 6-9 kW Connection Diagram

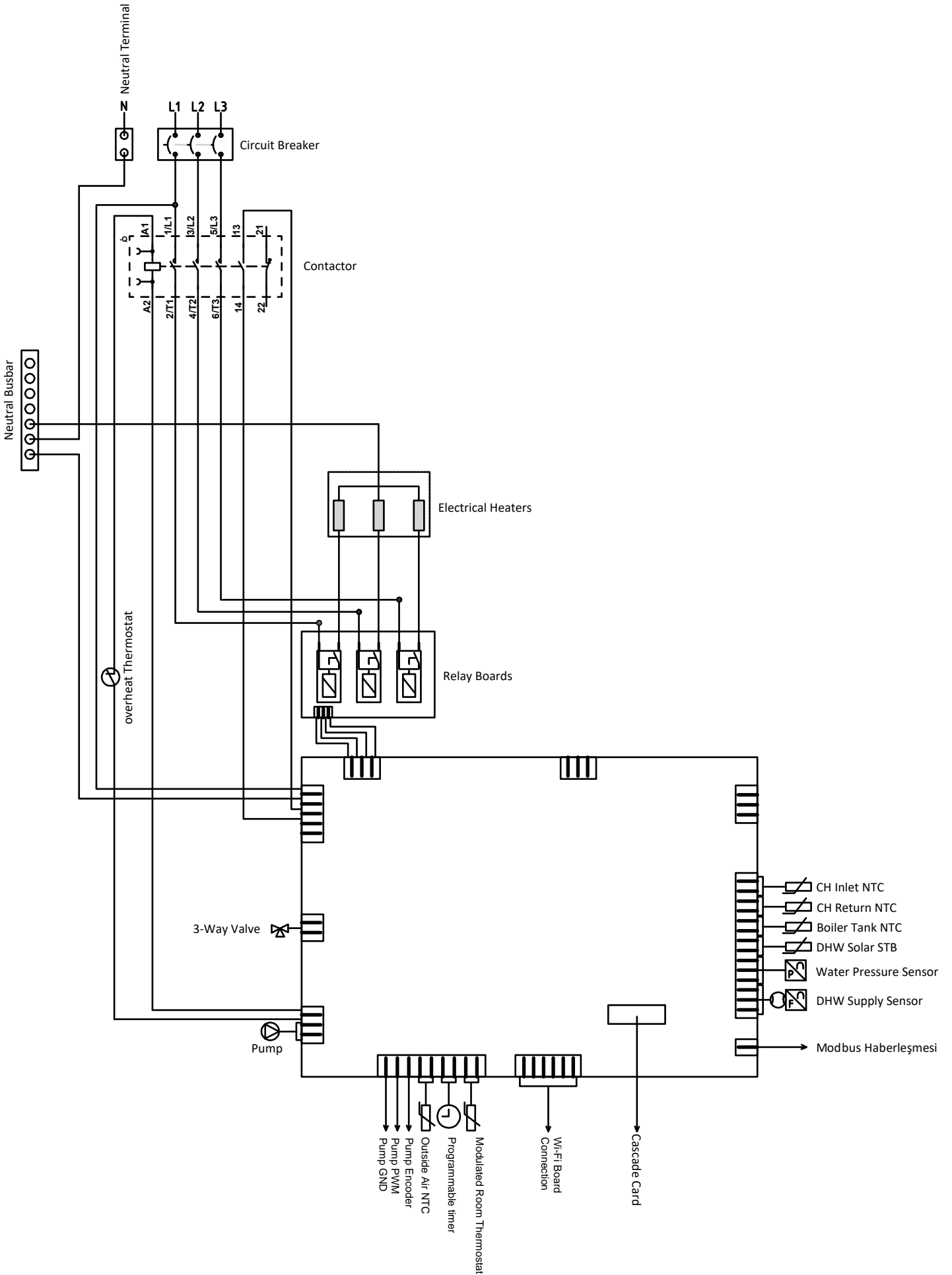

# 1.4.2.12-15 kW Connection Diagram

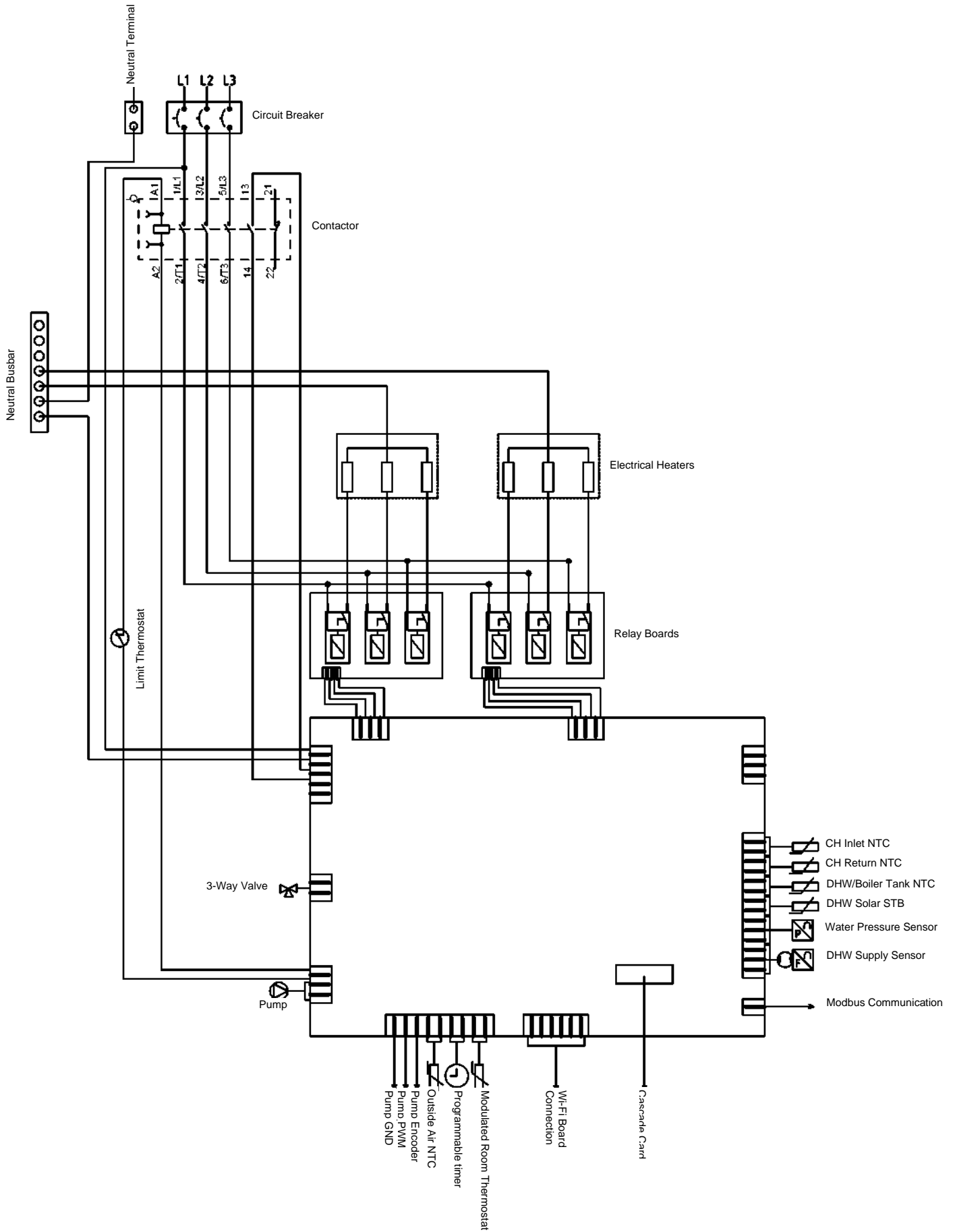

# 1.4.3.18-24 kW Connection Diagram

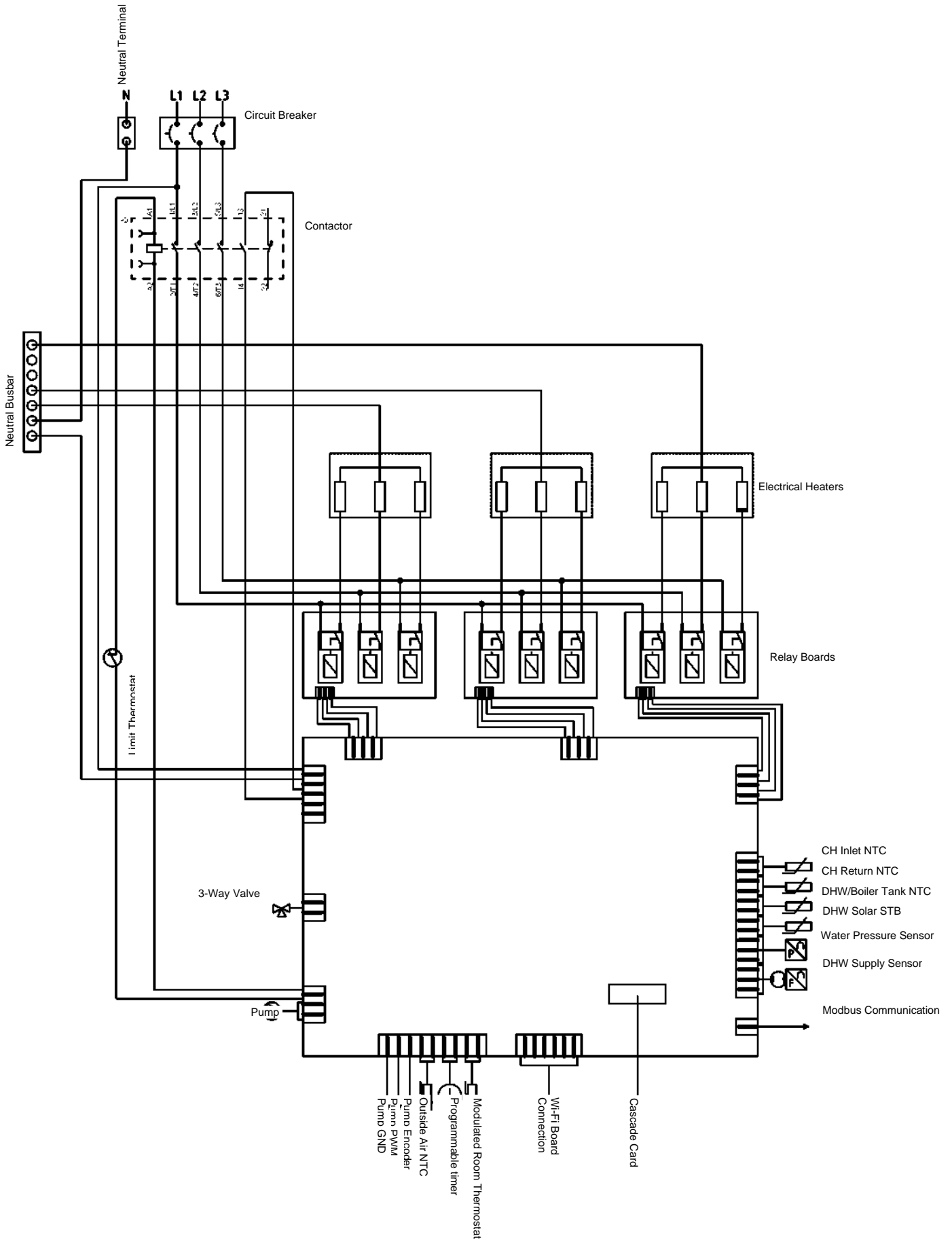

### 1.4.3. 27 kW Connection Diagram

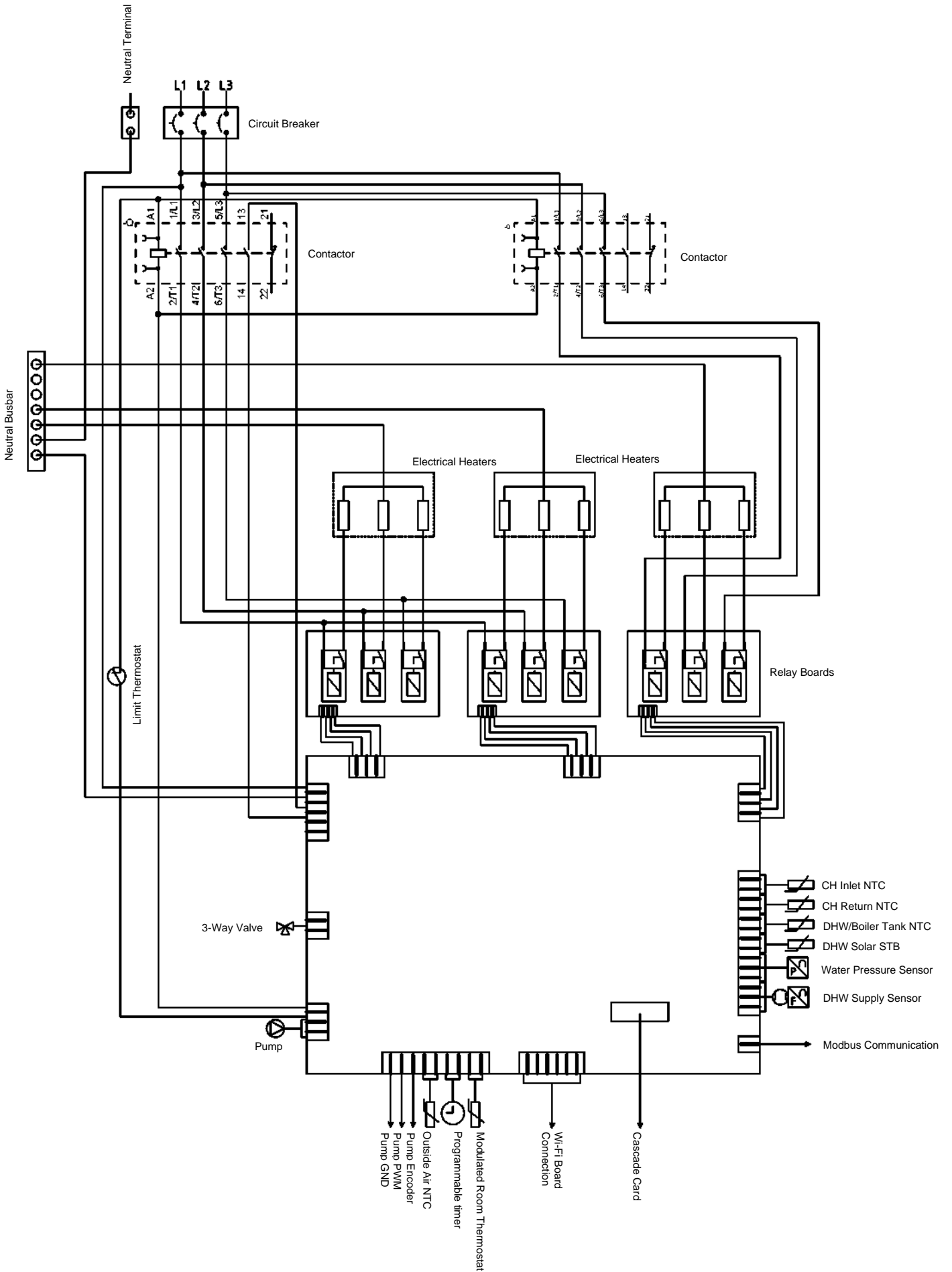

## 1.5. Detailed View and List of Components

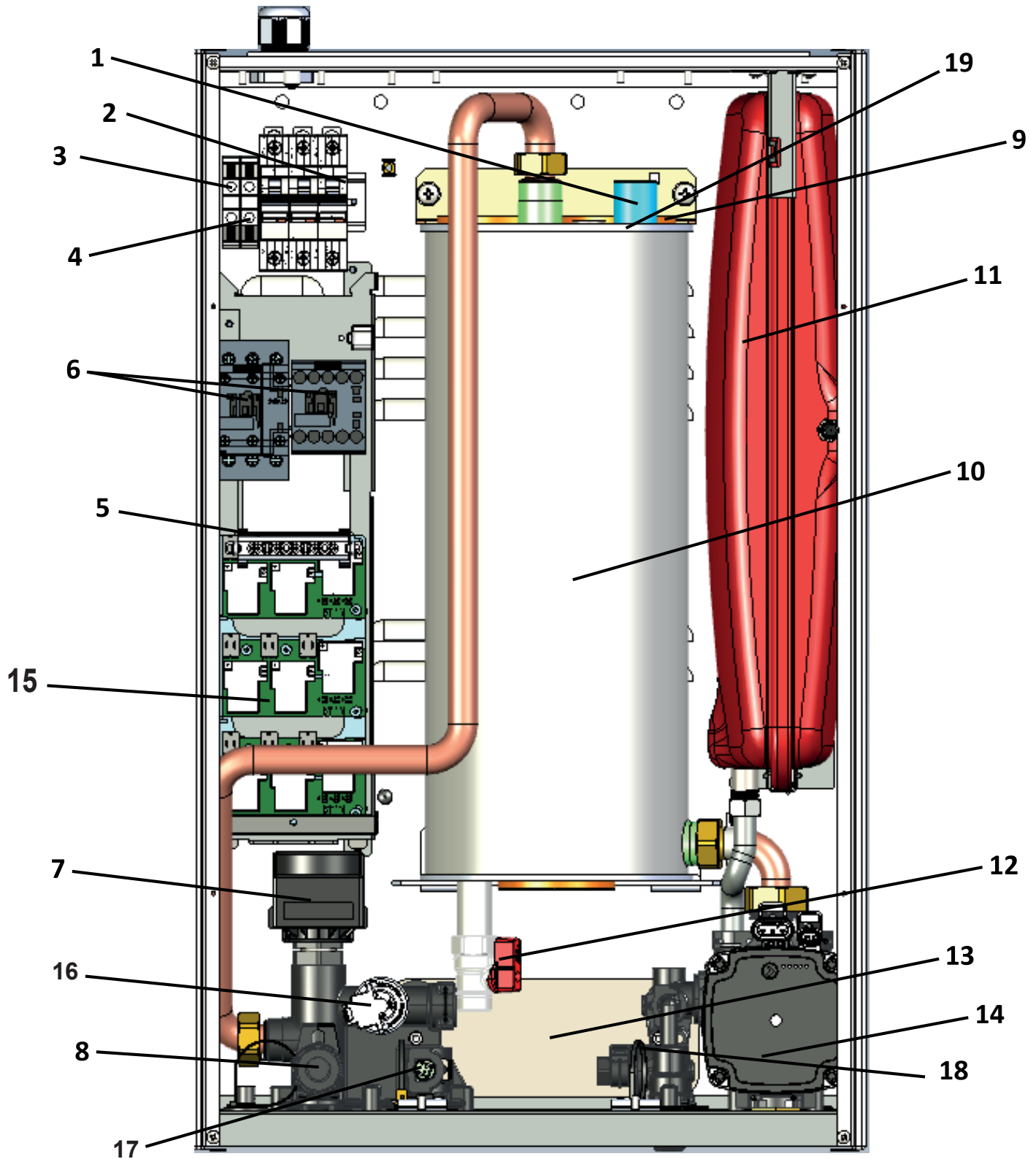

- |     |                        |     |                      |
|-----|------------------------|-----|----------------------|
| 1.  | Air Purge              | 11. | Expansion Vessel     |
| 2.  | Circuit Breaker        | 12. | Drain Valve          |
| 3.  | Ground Terminal Block  | 13. | Plate Heat Exchanger |
| 4.  | Neutral Terminal Block | 14. | Circulation Pump     |
| 5.  | Neutral Busbar         | 15. | Relay Boards         |
| 6.  | Cantactor              | 16. | Pressure Sensor      |
| 7.  | 3 Way Valve            | 17. | Immersion type NTC   |
| 8.  | 3 Bar Safety Valve     | 18. | Flow sensor          |
| 9.  | Electric Heaters       | 19. | Overheat thermostat  |
| 10. | Main Heat Exchanger    |     |                      |

## 1.6. Power Supply Connection Requirements

Device	Power Supply	Supply Cord (mm <sup>2</sup> )	Nominal Current (A)	Supply Line Minimum Circuit Breaker Capacity
<b>ARCEUS 6 CH-ST</b>	Single-phase	3x6	26	B32-1P
	Three-phase	5x2.5	9	B10-3P
<b>ARCEUS 9 CH-ST</b>	Single-phase	3x10	39	B40-1P
	Three-phase	5x2.5	13	B15-3P
<b>ARCEUS 12 MT-CH-ST</b>	Single-phase	3x10	52	B63-1P
	Three-phase	5x4	17	B20-3P
<b>ARCEUS 15 MT-CH-ST</b>	Single-phase	3x16	65	B80-1P
	Three-phase	5x6	21	B25-3P
<b>ARCEUS 18 MT-CH-ST</b>	Three-phase	5x6	26	B32-3P
<b>ARCEUS 24 MT-CH-ST</b>	Three-phase	5x6	35	B40-3P
<b>ARCEUS 27 MT-CH-ST</b>	Three-phase	5x10	39	B40-3P

**Table 2. Power Supply Connection Requirements**

## 2. Error Codes and Solutions

### 2.1. Solutions for Coded Errors

ERROR CODE	ERROR TYPE	DESCRIPTION	TYPE	SOLUTION
E03	Limit Thermostat Protection Error	This error is received, if one of the central heating inlet or return temperature sensors reads over 107°C. The error should be reset when the temperature drops to 85°C.	LOCKOUT	<ol style="list-style-type: none"> <li>1- Reset the error.</li> <li>2- Measure between the terminals of the overheat thermostat. If it is not short-circuit, wait for the tank to cool. If there is no short-circuit between the terminals despite the cooling of the tank, replace the overheat thermostat and reset the error.</li> <li>3- If the overheat thermostat terminals are measured open-circuit, check the pump connections. If the pump cables are connected, make sure that the pump circulates the water while it is energised. If the pump is pressurising the water normally, there may be a blockage in the heating circuit or the valves may be closed.</li> <li>4- Make sure the motorised valve works normally and moves the pin to switch between domestic water and central heating.</li> <li>5- If this error is received, although there is a short-circuit between the terminals of the overheat thermostat, measure the AC voltage between the terminals A1 and A2 of the contactor. If it is close to 230 VAC, check the presence of energy at NO contact terminals no. 13 and 14 with the voltage tester.</li> <li>6- If one of the terminals no. 13 and 14 is energised and the other is not, replace the contactor, if neither is energised, check the end-to-end integrity of the feedback cables. If the cables are broken or damaged, replace the high voltage cable group.</li> <li>7- If the parts are found to be solid after all the checks,</li> </ol>
E04	Faulty contactor feedback	If a false feedback is received even though the contactor should not be active, this error is displayed. A RESET operation is required after the error is corrected.	LOCKOUT	<ol style="list-style-type: none"> <li>1- Reset the error.</li> <li>2- If you still receive the error after reset, make sure that the contactor feedback cables are connected to terminals no. 13 and 14.</li> <li>3- If the error persists even though the feedback cables are connected to the correct terminals, measure the resistance between terminals no. 13 and 14 when the contactor is not energised. If a value other than open-circuit is displayed, replace the contactor.</li> <li>4- If the contactor is steady, check the end-to-end integrity of the feedback cables.</li> <li>5- If the cables are also solid, the mainboard must be replaced.</li> </ol>
E13	Too Frequent Error Reset Error	This error is received when 5 errors are reset within 1 hour. Domestic water and central heating requests are stopped. This error can be deleted by simply cutting off the power supply to the motherboard.	LOCKOUT	The error is corrected by turning off and on the Circuit Breaker inside the device or a cutting element in the front of the supply line.
F33	Central Heating Return Temperature Sensor Error	This error is received if the central heating return temperature sensor is short-circuit, open-circuit, or damaged. Domestic water and central heating request is stopped. When this error is deleted, normal operation begins.	ERROR	<ol style="list-style-type: none"> <li>1- Make sure the NTC cables in the return water line are plugged in.</li> <li>2- If the cables are plugged in, check the cables end-to-end. Make sure the cables are undamaged and plugged into the mainboard terminal. If there is a damaged wire, replace the low voltage cable group.</li> <li>3- If the cables are not damaged, measure the resistance between the terminals of the NTC and check that their values are appropriate.</li> <li>4- If the resistance value between the NTC terminals is according to the table, replace the return and supply water NTCs. If the error code does not change, replace the mainboard. If the error code becomes F35, replace the return water NTC.</li> </ol>
F34	Low Voltage Error	This error is received if the supply line voltage is below 170 ±15 VAC. This error is corrected if the line voltage is above 180 ± 15 VAC.	ERROR	<ol style="list-style-type: none"> <li>1- Measure the AC voltage between the phase and neutral terminals of the mainboard. If the voltage value is above 195 VAC, check the voltage of the line and wait for it to increase.</li> <li>2- If the voltage value is above 195 VAC,</li> </ol>

F35	Central Heating Inlet Temperature Sensor Error	This error is received if the central heating inlet temperature sensor is short-circuit, open-circuit, or damaged. Domestic water and central heating request is stopped. When this error is deleted, normal operation begins.	ERROR	<ol style="list-style-type: none"> <li>1- Make sure that the cables of the NTC in the supply line are connected.</li> <li>2- If the cables are plugged in, check the cables end-to-end. Make sure the cables are undamaged and plugged into the mainboard terminal. If there is a damaged wire, replace the low voltage cable group.</li> <li>3- If the cables are not damaged, measure the resistance between the terminals of the NTC and check that their values are appropriate.</li> <li>4- If the resistance value between the NTC terminals is according to the table, replace the return and supply water NTCs. If the error code does not change, replace the mainboard. If the error code becomes F35, replace the return water NTC.</li> </ol>
F37	Low Water Pressure	FP11 water pressure parameter is at a low level. This error is received if the water pressure is less than FP11/10 bar. The error is automatically deleted when the water pressure is more than (FP11/10+0.4 bar).	ERROR	<ol style="list-style-type: none"> <li>1- Fill the pipeline with water by opening the filling tap.</li> <li>2- If the pressure does not increase above 0.8 bar and the error does not disappear after the filling tap is opened, make sure that the valve is functioning mechanically. If the tap is faulty, replace it.</li> <li>3- If the filling tap is also intact, make sure that the water pressure in the plumbing is sufficient.</li> <li>4- If the plumbing pressure is also suitable, make sure that the cabling of the pressure sensor is undamaged and plugged in. If the cabling is suitable, replace the pressure sensor.</li> <li>5- If the problem is not solved by replacing the sensor, replace the mainboard.</li> </ol>
F39	Outdoor Temperature Sensor Error	This error is received if the outdoor temperature sensor is short-circuit, open-circuit, or damaged. Domestic water and central heating request is stopped. When this error is deleted, normal operation begins.	ERROR	<ol style="list-style-type: none"> <li>1- Reset the error.</li> <li>2- If the error does not disappear after reset, make sure that the outdoor sensor cables are connected.</li> <li>3- If the cables are undamaged and connected properly, replace the outdoor sensor.</li> <li>4- If the error persists after replacing the sensor, replace the mainboard.</li> </ol>
F40	High Water Pressure	FP12 water pressure parameter is at a high level. This error is received if the water pressure is more than $3.3 \pm 0.3$ bar. The error is automatically deleted when the water pressure is less than $3.3 \pm 0.3$ bar.	ERROR	<ol style="list-style-type: none"> <li>1- Check if the error disappears by draining the water from the heating installation.</li> <li>2- If the pressure does not drop below <math>3.3 \pm 0.3</math> bar after draining the water and the error does not disappear, check the cabling of the pressure sensor.</li> <li>4- If the cabling of the pressure sensor, replace the pressure .</li> <li>5- If the problem persists after replacing the pressure sensor, replace the mainboard.</li> </ol>
F47	Water Pressure Sensor Error	This error is received if the pressure sensor is short-circuit, open-circuit, or damaged. When this error is deleted, normal operation begins.	ERROR	<ol style="list-style-type: none"> <li>1- Check the cabling of the pressure sensor. If all cables are connected and undamaged, replace the pressure sensor.</li> <li>2- If the error persists after replacing the pressure sensor, replace the mainboard.</li> </ol>
F50	Solar Energy Boiler Tank Temperature Sensor Error	This error is received if the solar energy boiler tank temperature sensor is short-circuit, open-circuit, or damaged. Domestic water and central heating request is stopped. When this error is deleted, normal operation begins.	ERROR	<ol style="list-style-type: none"> <li>1- Reset the error.</li> <li>2- If the error persists after reset and you are not using boiler or solar energy tank, make sure P00 parameter is not 2, 3 or 4. If you are using boiler or solar energy tank, make sure the cabling of the temperature sensor is undamaged and assembled.</li> <li>3- If the cables are undamaged and connected properly, replace the sensor.</li> <li>4- If the error persists after replacing the sensor, replace the mainboard.</li> </ol>
F51	Solar Panel Temperature Sensor (PT1000) Error	This error is received if the solar panel temperature sensor (PT1000) is short-circuit, open-circuit, or damaged. Domestic water and central heating request is stopped. When this error is deleted, normal operation begins.	ERROR	<ol style="list-style-type: none"> <li>1- Reset the error.</li> <li>2- If the error persists after reset and you are not using solar energy panel, make sure P00 parameter is not 2, 3 or 4. If you are using solar energy panel, make sure the cabling of the temperature sensor is undamaged and assembled.</li> <li>3- If the cables are undamaged and connected properly, replace the sensor.</li> </ol>



## 2.2. Solutions for Functional Faults of Device

### 2.2.1. In case the heater circuit of the device underheats or does not heat at all:

1- Put the device into test mode by pressing and holding K3 and K5 together for 5 seconds. When the device is put into test mode, "FT" will be displayed on the screen. In this case, measure the current through the resistor neutral cables using a clamp meter and detect whether there is a dead resistor.

2- If there is no dead resistor in test mode, there is no need to control power circuit elements such as the mainboard, relay boards, resistors and contactors. In this case, the control sensors and hydraulic equipment must be checked.

a- First, check the piping connections and make sure that the central heating valves outside the boiler are turned on. If the valves are turned on, remove the motorised valve from the device and make sure its pin is pressed. While the pin of the motorised valve is pressed, it sends water to the heater circuit. b- If the motorised valve is in its normal position, check that the heater installation is not blocked. c- If there is no blockage in the plumbing, check the temperatures of "i00 central heating supply water" and "i01 central heating return water" from the information menu and observe if there is an incorrect measurement. If there is an incorrect measurement, relocate the NTCs and check if the supply or return water temperature measurement has improved. If it does, replace the NTC that has problem in measurement. If not, remove the NTC and measure the resistance and check whether the measurement is according to the table. If the measurement is correct, a mainboard replacement may be required.

3- If there is a dead resistor or a dead cable in test mode, follow the steps below:

a- Check whether there is voltage at the output contacts no. 2, 4 and 6 of the contactor with the voltage tester by opening the switch cover. Replace the contactor if there is no voltage in any of the three contacts although the input poles of the contactor are energised and the measured voltage difference between the terminals A1-A2 of the contactor is 180-240 VAC.

b- Disconnect the input power supply of the device and check whether there is deformation or loose contact in the phase and neutral cables of the dead resistor.

c- If there is no deformation in the cables, measure between the phase terminals of the resistors and the neutral busbar after disconnecting the input power supply of the device and make sure that all the resistors are in the correct resistance range. The required resistance value range is as follows:

Part Code		Part Code	
7006250005		7006250004	
Maximum overheat ( $\Omega$ )	Minimum overheat ( $\Omega$ )	Maximum overheat ( $\Omega$ )	Minimum overheat ( $\Omega$ )
19	16	28	24

d- If there is no loose contact in the cables and the resistance of the resistors are within normal values, take measurements from other resistors in the same group. If all the resistors in a single resistor group are dead, check that the relay trigger cables are undamaged and connected to both the mainboard and relay board sides. On the mainboard, these cables should be connected to the following ports:

- For 6 and 9 kW devices: "Relay Group 1"
- For 12 and 15 kW devices: "Relay Group 1" and "Relay Group 2",
- For 18, 24 and 27 kW devices: "Relay Group 1", "Relay Group 2" and "Relay Group 3".

e- If the connections are correct, disconnect the input electricity supply of the device from the Circuit Breaker, disconnect the dead resistor cables from the relay boards and unplug them, and turn on the Circuit Breaker again and put the device into test mode with K3 and K5. While the device is in test mode, measure the resistance between the pins you disconnected. If you're reading a resistance close to 0 between the relay pins, the relay board and mainboard are steady.

f- If you see the open-circuit ("OL") value between the relay pins, look at the LEDs on the relay board and check if the lamps are lit.

g- If the lamps are on and "OL" (open-circuit) is still displayed on the screen, replace the relay board.

h- If the trigger cable is properly connected but the LED lamp does not light, plug the trigger cable into the port of another relay board and recheck the LED lamps.

- If the lamps of new relay board light, the problem will be solved by replacing the relay board.
- If the LEDs of the new relay board do not light, replace the mainboard.
- Put the device in test mode after the part replacements, and check if the resistors are activated.

## 2.2.2. In case the device underheats or does not heat domestic water at all:

1- Put the device into test mode by pressing and holding K3 and K5 together for 6 seconds. When the device is put into test mode, "FT" will be displayed on the screen. In this case, measure the current through the resistor neutral cables using a clamp meter and detect whether there is a dead resistor.

**2- If there is no dead resistor in test mode**, there is no need to control power circuit elements such as the mainboard, relay boards, resistors and contactors. In this case, the control sensors and hydraulic equipment must be checked.

A- First, remove the motorised valve on the device and check whether the pin goes in when the flow passes through the device. If the pin is going in, check the spring suppressed by the motorised valve in the supply manifold. If the spring is faulty and cannot be repaired, replace the supply manifold,

b- If the pin is not going in:

- If the flow rate appears to be at its normal value, follow the steps described in the title 4.9 "Voltage and Position Control in Domestic Water Heating". If voltage values are normal, replace motorised valve.

- If the voltage value is not as it should be in the domestic water position, read the "i05 Domestic water flow rate (L/min.)" information from the information menu. If the flow rate is displayed as "0" even though water is passing through the domestic water circuit, make sure that the flow sensor is installed correctly. If a value of "0" or less is displayed even though the flow sensor is installed, replace the flow sensor.

c- If the pin of the motorised valve completes the action normally, make sure that the submersion type NTC on the hydroblock is installed correctly. If the NTC is installed properly, check the "i02 domestic water instantaneous temperature" value in the information menu. If the value is incorrect, replace the NTC.

**3- If there is a dead resistor or a dead cable in the test mode**, follow the steps below (you can see the images related to the measurements in this section in the 3rd item of the title 2.2.1).

a- Check whether there is voltage at the output contacts no. 2, 4 and 6 of the contactor with the voltage tester. Replace the contactor if there is no voltage in any of the three contacts although the input poles of the contactor are energised and the measured voltage difference between the terminals A1-A2 of the contactor is 180-240 VAC.

b- Disconnect the input power supply of the device and check whether there is deformation or loose contact in the phase and neutral cables of the dead resistor.

c- If there is no deformation in the cables, measure between the phase terminals of the resistors and the neutral busbar after disconnecting the input power supply of the device and make sure that all the resistors are in the correct resistance range. The required resistance value range is as follows:

Part Code		Part Code	
7006250005		7006250004	
Maximum Limit( $\Omega$ )	Minimum Limit( $\Omega$ )	Maximum Limit( $\Omega$ )	Minimum Limit( $\Omega$ )
19	16	28	24

d- If there is no loose contact in the cables and the resistance of the resistors are within normal values, take measurements from other resistors in the same group. If all the resistors in a single resistor group are dead, check that the relay trigger cables are undamaged and connected to both the mainboard and relay board sides. On the mainboard, these cables should be connected to the following ports:

- For 6 and 9 kW devices: "Relay Group 1"

- For 12 and 15 kW devices: "Relay Group 1" and "Relay Group 2",

-For 18, 24 and 27 kW devices: "Relay Group 1", "Relay Group 2" and "Relay Group 3".

- e- If the connections are correct, disconnect the power of the device from the Circuit Breaker, disconnect the dead resistor cables from the relay boards and unplug them, and turn on the Circuit Breaker again and put the device into test mode with K3 and K5. While the device is in test mode, measure the resistance between the pins you disconnected.
- f- If you see the open-circuit ("OL") value between the relay pins, look at the LEDs on the relay board and check if the lamps are lit.
- g- If the lamps are on and "OL" (open-circuit) is still displayed on the screen, replace the relay board.
- H- If the trigger cable is properly connected but the LED lamp does not light, plug the trigger cable into the port of another relay board and recheck the LED lamps.
  - If the lamps of new relay board light, the problem will be solved by replacing the relay board.
  - If the LEDs of the new relay board do not light, replace the mainboard.
  - Put the device in test mode after the part replacements, and check if the resistors are activated.

### **2.2.3. What to Do in if Comfort Mode Does not Work**

When the device is in comfort mode, the water in the exchanger tank is kept at the domestic water set temperature. When the device is in comfort mode, the water in the tank is heated at minimum with a single resistor inside the device. Check the relays after you see the tap icon blinking on the screen of the device in comfort mode. The LED of one of the relays should light up. Measure the current with a clamp meter through the cables from the contacts of the relay whose LED is lit. If they are not dead, the comfort mode of the device is operating. If the resistor that needs to heat is dead in this case, measure this resistor in accordance with the 3rd item of the title 2.2.1.

### **2.2.4. What to Do if the Device's Circuit Breaker Blows**

- 1- Disconnect the input power supply of the device and observe if there is any physical deformation in any cable. If there is a deformed cable, replace it.
- 2- Check if there is a physical deformation such as burning by checking the Circuit Breaker. If the Circuit Breaker is deformed, replace it.
- 3- Open the control panel and check if the glass Circuit Breaker of mainboard is intact. If the glass Circuit Breaker of mainboard is blown and its terminals are open-circuit:
  - a- Disconnect all the external connections of the connector with the power cable by replacing the glass Circuit Breaker of the device, and re-energise the device.
  - b- In this case:
    - If the glass Circuit Breaker is not lit, measure the resistance between the phase and neutral terminals of the pump, motorised valve, terminals A1 and A2 of the contactor coil, A1 and A2 terminals of the relays on the board to detect the short-circuited part and replace it. After replacing and reconnecting the parts, operate the device in DHW and CH heating modes.

- If the glass Circuit Breaker is lit, measure the resistance between the phase and neutral terminals of the pump, motorised valve, terminals A1 and A2 of the contactor coil, A1 and A2 terminals of the relays on the board to detect the part that may caused the short-circuit and replace it. If a part that may caused the short-circuit is not detected after the checks, replace the mainboard and turn the device back on.

4- If the glass Circuit Breaker of the mainboard is intact, measure the resistance between the contactor output contacts (contacts no. 2, 4 and 6) while the voltage supply of the device is off and observe if there is a short-circuit. If there is a short-circuit, disconnect the connections to find the condition in which the short-circuit is eliminated, and replace the cable or contactor that caused the short-circuit.

5- If there is no short-circuit, measure the resistance between the phase input terminals of all the resistors and the neutral busbar, and check if there is a short-circuit. If one of the terminal of the resistors is short-circuited, replace the resistor.

6- If a short-circuit condition is not detected after checking the resistors, restart the device and run it at full load for 10 minutes. If the Circuit Breaker does not blow during this time, turn the device on. The reason for blowing the Circuit Breaker may be that the environment where the boiler is located is too hot or phase fluctuations in the grid voltage.

7- If this happens more than once, the Circuit Breaker may be faulty and its replacement may be required.

### **3. ASSEMBLY/DISASSEMBLY PROCEDURES OF PARTS**

#### **3.1. Front Panel**

In order to remove the front panel, firstly the connecting screws at the bottom must be unscrewed and then the panel should be removed by lifting it from below.

**Suitable Hand Tool: Cross-screwdriver**

#### **3.2. Side Panels**

They should be opened to the side by unscrewing the connection screws at the top and bottom, and then removed.

**Suitable Hand Tool: Cross-screwdriver**

#### **3.3. Contactor**

To remove the contactor on the rail, hold the contactor and push it slightly upwards so that the spring mechanism behind it is released from the rail and remove the contactor.

A cross-screwdriver should be used to remove the cable connections.

**Suitable Hand Tool: Cross-screwdriver**

**Suitable Tightening Torque: Main Contact Connections: 2.25±0.25 Nm**

**Auxiliary Contact and Coil Connections: 1±0.2 Nm**

### **3.4. Circuit Breaker**

Pull the flanges under the circuit breaker down with the help of a screwdriver so that they can be removed from the rail. When installing the Circuit Breaker to the rail, you can first insert the tabs of the upper part of the Circuit Breaker into the rail and then push the lower part towards the rail. The cables can be replaced with a cross-screwdriver.

**Suitable Hand Tool: Cross-screwdriver**

### **3.5. Neutral Busbar**

Contact and foot of the neutral busbar should be assembled/disassembled with a cross-screwdriver.

**Suitable Hand Tool: Cross-screwdriver**

**Suitable Tightening Torque: Contact Connections:  $0.8\pm 0.1$  Nm**

**Neutral Busbar Assembling Foot:  $0.5\pm 0.1$  Nm**

### **3.6. Supply-Return Manifold**

For manifold replacement, the connection screws on the lower panel must be removed.

**Suitable Hand Tool: Cross-screwdriver**

### **3.7. Pump**

For pump disassembly, its screw connection with the bottom panel, and the heat exchanger tank return duct connections must be removed.

**- For Assembling the Return Duct:**

**Suitable Hand Tool: AA 36 Wrench**

**- For the screw connection of bottom panel:**

**Suitable Hand Tool: Cross-screwdriver**

The air purge of the pump can be removed with a clip.

### **3.8. Air Purge**

**Suitable Hand Tool: AA 23 Wrench**

### **3.9. Overheat Thermostat**

**Suitable Hand Tool: AA 17 Wrench**

### 3.10. Mainboard

The mainboard can be disassembled by removing the screws and connectors at the 4 corners of the mainboard.

**Suitable Hand Tool: Cross-screwdriver**

**Suitable Tightening Torque: 0.5±0.1 Nm**

### E.C.A. ARCEUS ELECTRIC COMBI MAINBOARD PARAMETER ADAPTATION

The mainboard is defined as a single spare part code for all capacities and configurations (Spare Part Code: 7006250015). Therefore, capacity and configuration adjustments are required on the replaced mainboards. The values to be adjusted are provided in the table below:

Device Type	Capacity	Parameter	
		P00	FP22
MT	12 kW		12
	15 kW		15
	18 kW		18
	24 kW		24
	27 kW		27
ST	6 kW	3	6
	9 kW	3	9
	12 kW	3	12
	15 kW	3	15
	18 kW	3	18
	24 kW	3	24
	27 kW	3	27
CH	6 kW	5	6
	9 kW	5	9
	12 kW	5	12
	15 kW	5	15
	18 kW	5	18
	24 kW	5	24
	27 kW	5	27

The steps to follow for mainboard replacement are as follows:

## Adjusting Boiler Capacity

While the device is on the normal operation screen, the service menu is accessed by pressing the mode selection button (K1) for 5 seconds.

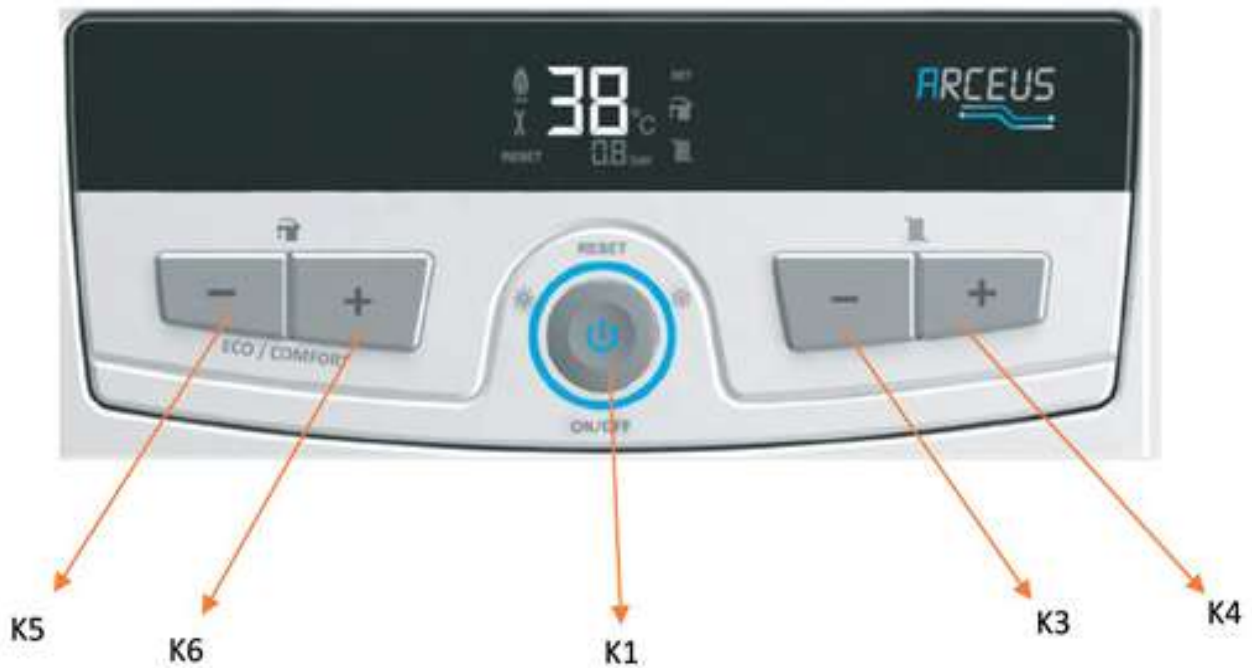

When "tS" symbol is displayed on the screen, press K1 once again to access the password entry screen.

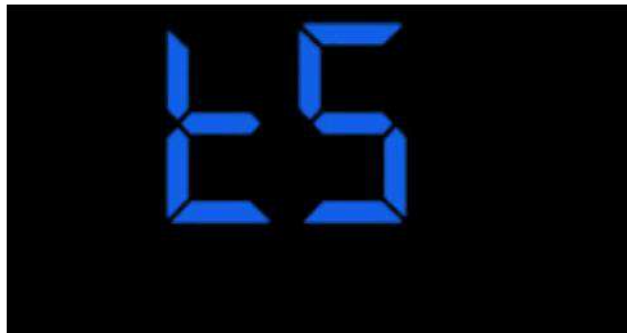

The number 15 is selected with the heater water temperature adjustment buttons and the password is confirmed with one of the domestic water adjustment buttons (K5 or K6). When the FP22 capacity selection screen is displayed, the capacity value is set with K3 and K4.

After selecting the desired capacity value, press and hold K1 for 5 seconds to return to the main operation screen.

## Adjusting Boiler Configuration

The service menu is accessed by pressing the mode selection button (K1) for 5 seconds.



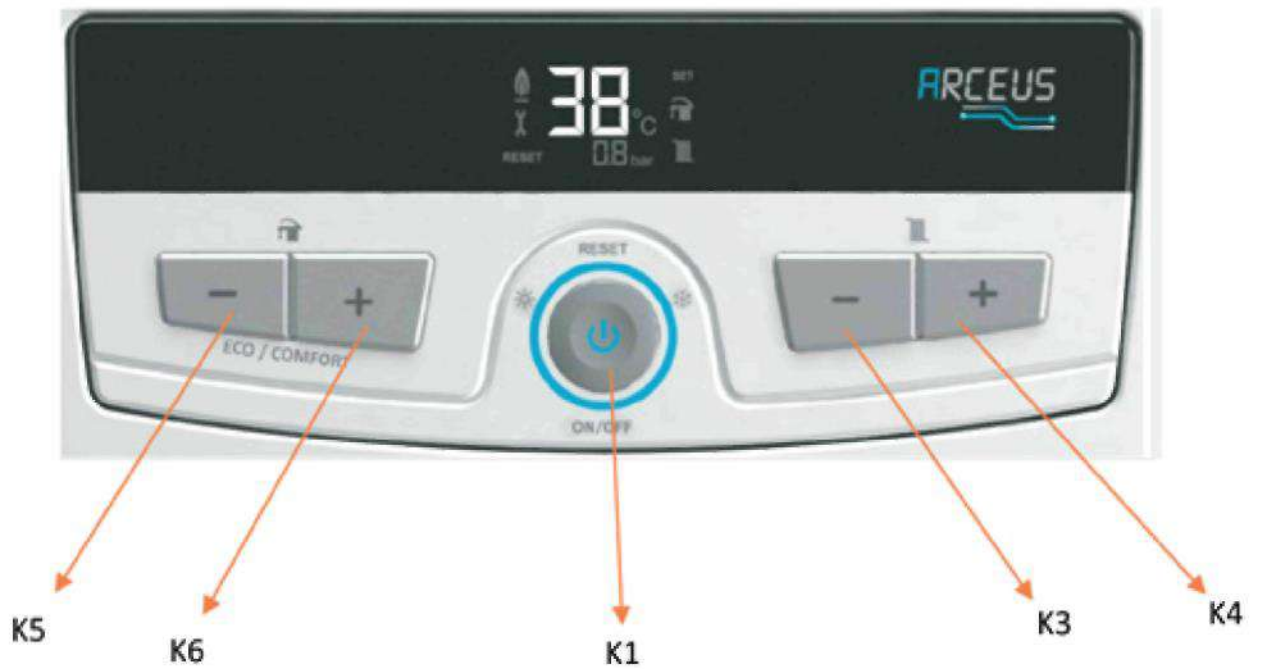

When "tS" symbol is displayed on the screen, press K1 once again to access the password entry screen.

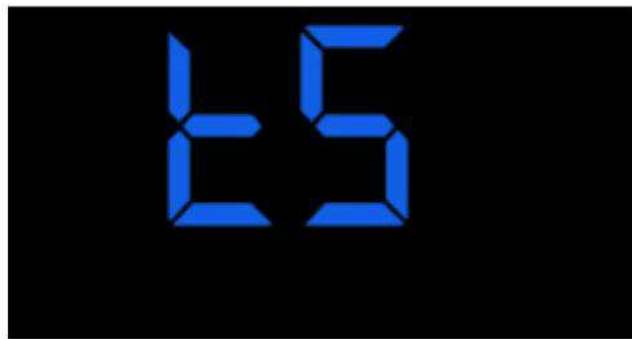

The number 03 is selected with the heater water temperature adjustment buttons and the password is confirmed with one of the domestic water adjustment buttons (K5 or K6). The values "P" and "00" will blink alternately on the screen. At this stage, the value "1" is selected with K3 and K4 and the boiler is set to "MT".

Then, you can return to the main screen by pressing and holding K1 for 5 seconds.

### **3.11. Relay Boards**

Relay boards can be disassembled by removing 3 screws and contact connections.

**Suitable Hand Tool: Cross-screwdriver**

### **3.12. Expansion Tank**

**- For removing the holdfast:**

**Suitable Hand Tool: Cordless screwdriver**

**- For removing the flex hose:**

**Suitable Hand Tool: AA 18 Wrench**

### **3.13. Inlet Duct**

**- For both sides:**

**Suitable Hand Tool: AA 30 Wrench**

### **3.14. Return Duct**

**- Tank side**

**Suitable Hand Tool: AA 30 Wrench**

**- Pump side**

**Suitable Hand Tool: AA 36 Wrench**

### **3.15. 3 Bar Safety Valve**

The 3 Bar safety valve clip can be disassembled by removing its clip.

### **3.16. Drain Valve**

### **3.17. Motorised Valve**

You can disassemble the motorised valve by removing its clip.

### **3.18. Submersion Type NTC**

You can disassemble the submersion type NTC by removing its clip.

### **3.19. Plate Exchanger**

After removing the manifold connections of the plate exchanger with a size 4 hex key, you can push the exchanger back and remove it from the lower service cover.

**Suitable Hand Tool: Size 4 Hex Key**

### **3.20. Main Exchanger Tank**

After removing all the cable connections of the tank group, unscrew the screws of the upper connection bracket of the exchanger tank with a cordless drill and slowly tilt the tank to remove it.

**Suitable Hand Tool: Cordless screwdriver**

### **3.21. Switch Cover**

In cases where it is necessary to remove the switch cover for fault check, pull the cover slightly towards yourself, remove it from the hinge fitting and tilt it. Then you can take it out.

When putting the cover back on, fit the bottom flanges into the slots and make sure it locks into the hinge on the top right. The right and left upper panel ends of the cover must fit the inside of the rear body.

**3.22. Pressure Sensor Suitable Hand Tool: AA 17 Wrench**

### 3.23. Resistor Replacement

If one of the resistors is short- or open-circuited, the cables are deformed or another physical deformation occurs, the resistor may be replaced without removing the exchanger tank. For tank replacement, drain the water inside the tank with the drain valve, and loosen the resistor flange. Afterwards, disassembly the resistor to be replaced by removing the lower or upper service panel depending on whether the resistor is at the bottom or the top of the tank, install the new one into the same place of the device, and tighten the flange.

You can replace the resistor more easily by obtaining the 7006250177 coded resistor spring sleeve.

When tightening the phase inlet cables, M4 washer, cable terminal ring, M4 spring washer and M4 nut should be installed respectively. While turning the nut with the wrench from the top side, the terminal of the resistor should be fixed with a 1/4 inch wrench from the bottom side.

For phase cable assembly:

**Suitable Hand Tool: Hex-Box Wrench no. 7 and 1/4 inch open-end wrench**

**Suitable Hand Tool: AA 62 Wrench or 7006250177 Resistor Spring Sleeve**

**ATTENTION: In case of a resistor replacement, a resistor with the same capacity as the one that was removed must be installed. Otherwise, damage to the device or plumbing may occur.**

### 3.24. Controller and Sensor Connections

The end of the transition rubber is cut off and threaded into the thermostat cable.

The phase and neutral terminals of the thermostat cable are plugged into the terminal entries shown in controller connection diagram.

## Making Controller Connections

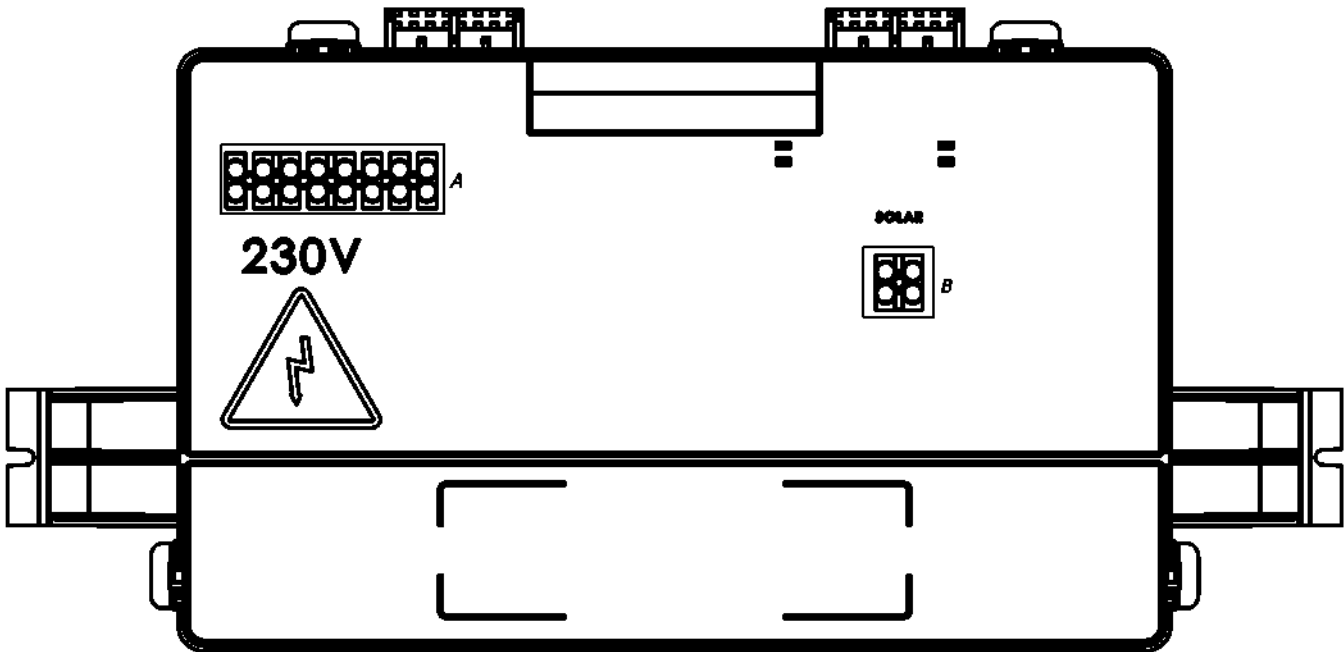
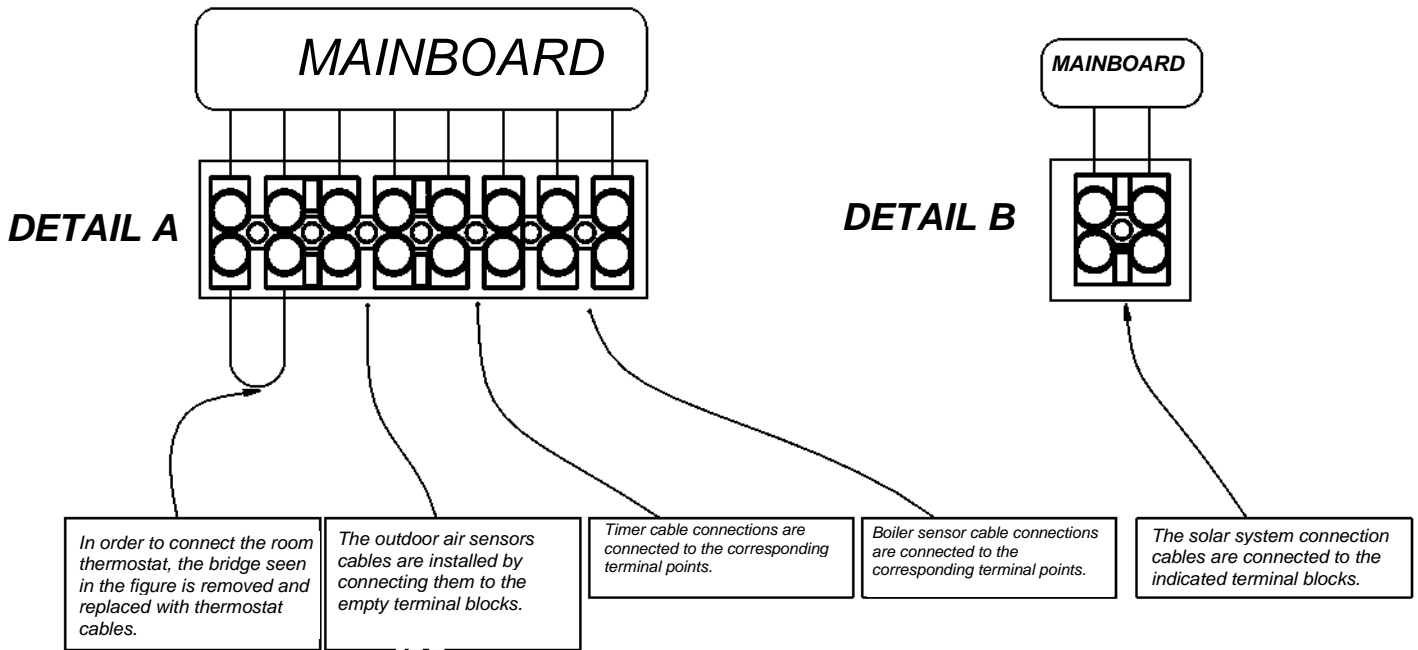

- Disconnect the bridge on the room thermostat connection.

## 4. PART DEFINITIONS AND ERROR TYPES

### 4.1. Heating Resistor

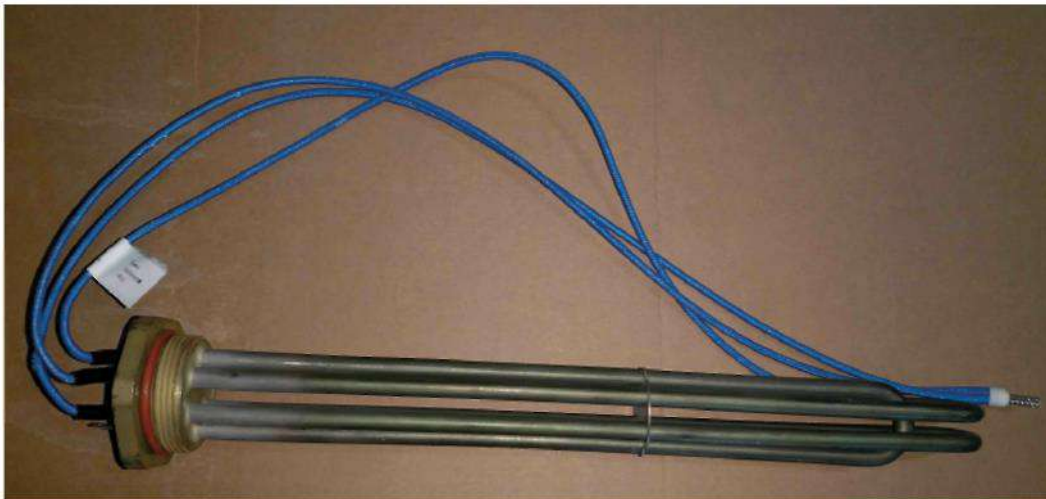

Subject	Description
Function of Part	It gives the electrical power burned on it to the tank as heat and provides heating of the water in the exchanger body.
Impact in Case of Malfunction;	1- The Circuit Breaker blows. 2- The device does not heat or heats below its capacity.
Main Associated Error Codes	-
Diagnostics and Test Method	End-to-end resistor measurement
Maintenance Requirement	During the annual routine maintenance, it should be disassembled and the lime build up on it should be observed. If there is a layer of build up lime on it, it should be cleaned by scraping with a non-metallic hard brush. The presence of build up lime on the resistor as in the photo does not mean that the part should be replaced. If the appropriate resistance value is measured after the measurement made between the ends, it can be used after cleaning.

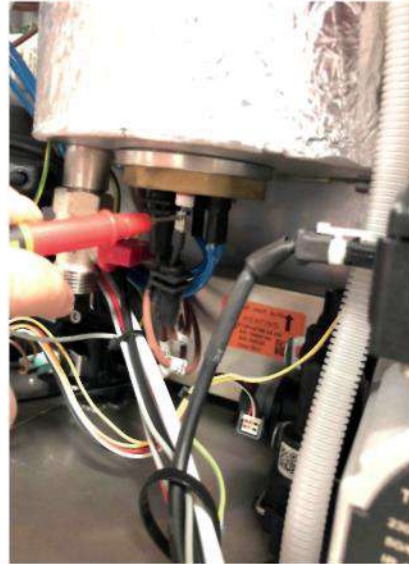
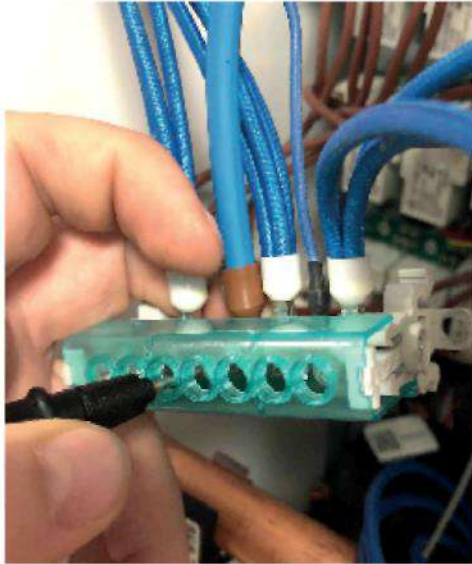

Test definition	Test Method
Resistance measurement	Resistance between each phase input terminal of the resistor and the neutral busbar or terminal is measured. This value should be in the range of 24-28 $\Omega$ for 6 kW resistor groups, and 16-19 $\Omega$ for 9 kW resistor groups.





## 4.2. Main Exchanger Tank

Subject	Description
Function of Part	It provides a heat exchange environment between the resistors mounted on it and the installation water.
Impact in Case of Malfunction	In case of water leakage, it may cause pressure drop in the plumbing and short-circuits in the device.
Main Associated Error Codes	
Diagnostics and Test Method	It should be checked whether there is any wear that may cause water leakage by observing the resistor, duct, purge and valve connection flanges.
Maintenance Requirement	In the annual routine maintenance, the exchanger is cleaned by circulating Sentinel X300 through the central heating installation.
<div style="display: flex; justify-content: space-around;">   </div>	
Test definition	Test Method
Observation of Tank Water Leakage Cause	Make sure that the water leakage in the tank is not caused by the mounted resistor, purge, duct or valves that are not tightened with sufficient torque. Then visually inspect the corresponding flange of the tank. The o-ring specified in the spare parts catalogue must be used in the resistor assembly.



### 4.3. Circuit Breaker

Subject	Description
Function of Part	It prevents the device and installation from being damaged by switching the circuit off in case of over-current.
Impact in Case of Malfunction	1- It blows when there is no over-current. 2- The power supply of the device is switched off incorrectly.
Main Associated Error Codes	-
Diagnostics and Test Method	Visual inspection, observation when operating at full load, and measurement from output poles.
Maintenance Requirement	There is no special maintenance requirement.
	
Test definition	Test Method
Output transmission control	Visually check if there is any deformation, burning, etc. in the contacts and body of the Circuit Breaker. With a voltage tester, confirm that the Circuit Breaker is conducting to the output contacts with the latch of the Circuit Breaker turned up.
	

## 4.4. Neutral Busbar

Subject	Description
Function of Part	It is a common connection point that provides the distribution of the neutral line entering from the neutral terminal on the device.
Impact in Case of Malfunction	The neutral line may not reach the resistors or the mainboard.
Main Associated Error Codes	-
Diagnostics and Test Method	Visual inspection, controlling whether there is burning on contacts and body, checking whether the feet are broken
Maintenance Requirement	There is no special maintenance requirement.



## 4.5. Mainboard

Subject	Description
Function of Part	It controls the execution of device functions in accordance with the algorithm and the peripheral equipment.
Impact in Case of Malfunction	1- Partial or complete loss of function of the device. 2- Displaying an incorrect error code on the main screen. 3- User display not working properly or not lit at all.
Main Associated Error Codes	-
Diagnostics and Test Method	Visual inspection of circuit elements, control of peripheral equipment
Maintenance Requirement	There is no special maintenance requirement.



## 4.6. Relay Board

Subject	Description
Function of Part	Commissioning the resistors by making the last stage switching and meeting the heating request.
Impact in Case of Malfunction	1- The device does not heat or heats below its capacity. 2- If it is stuck in the transmission, it can heat even though there is no heating request, and if there is no water circulation, it may cause an overheating error. 3- If there is a short-circuit between the relay coils, it will draw excessive current and damage the mainboard.
Main Associated Error Codes	E03
Diagnostics and Test Method	Coil resistance measurement, resistance measurement between contacts while they are on and off.
Maintenance Requirement	There is no special maintenance requirement.
Test definition	Test Method
Resistance measurement between coils.	Resistance between the coil terminals of the relay board is measured. When measuring between terminal no. 4 and other terminals, the short-circuit value should not be read. If the short-circuit value is read, there will be a risk of damaging the relay board to the mainboard. In such a case, the relay board must be replaced absolutely. Before the relay board replacement, the test specified in "Voltage measurement over the cable" should be applied in order to investigate the root cause and it should be determined that the problem is not caused by the cable. If the problem is caused by the cable, the cable should also be replaced.



Voltage measurement over the cable

Put the device in test mode. When FT is displayed on the screen, disconnect the relay board cables and measure the voltage. Touch the probe coming out of the  $V_{\Omega}$  port of the measurement tool to the cable entering the terminal no. 4 of the relay board, and touch the other end of the probe cable coming out of the common (COM) port and the other three cables. Voltage values should be between +(21-26) VDC. If this value is not displayed even though the cables are connected, replace the mainboard. If this value is -(21-26) VDC, the relay trigger cable may be reversed. In this case, the relay board trigger cable must be replaced. It will also damage the newly installed relay board and the mainboard.



Measurement of relay contacts

1- Put the device in test mode. When FT is displayed on the screen, measure the resistance between the relay contacts after you see that all the LED lamps on the relay board are lit. There must be a short-circuit between the contacts.  
2- Measure the resistance between the contacts when the relays are not activated. The value should be open-circuit.

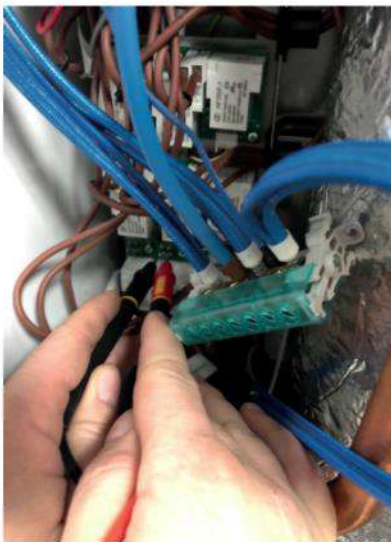



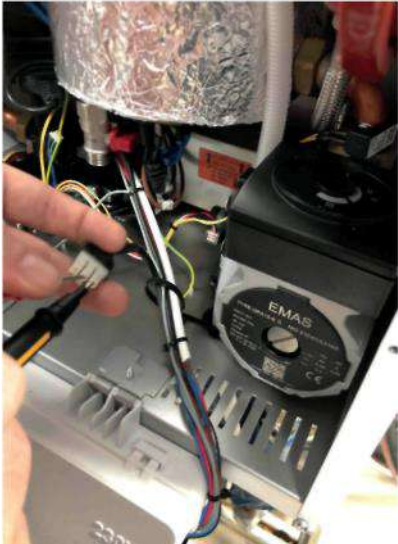

## 4.7. Pump

Subject	Description
Function of Part	It pressurises the water in the closed-circuit installation and provides water circulation. In addition, it ensures the removal of air in the installation with water circulation.
Impact in Case of Malfunction	1- The boiler gives overheating error. 2- Heated water does not transmitted to the installation. 3- The cryoprotection function does not work properly. 4- In case the air purge on the pump fails, water can be discharged instead of air and the installation pressure decreases.
Main Associated Error Codes	E03, F37, E80
Diagnostics and Test Method	1- Visual inspection of electrical connection. 2- Voltage measurement between phase and neutral inputs while the power is on. 3- Resistance measurement between phase and neutral inputs while the power is off.
Maintenance Requirement	There is no special maintenance requirement.
	
Test definition	Test Method
Voltage Measurement	In operating condition, the voltage measured between the blue and brown cables should be 210-240 VAC.
	
Resistance measurement	When the pump's cable is disconnected, there should be no short-circuit when the resistance is measured between the pins where the blue and brown cables are connected. If there is a short-circuit, it means that the pump motor has burned out.

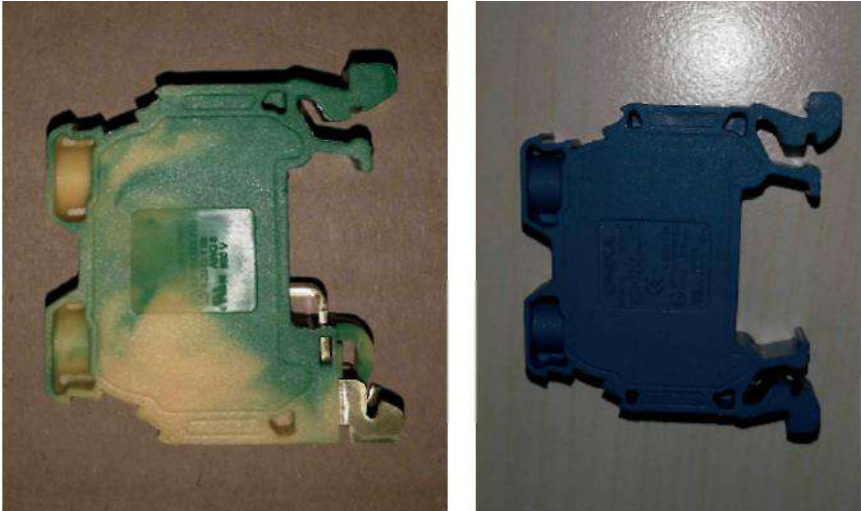
## 4.8. Neutral and Ground Terminals

Subject	Description
Function of Part	It provides the transmission and distribution of the neutral and grounding lines entering from the main supply of the device to the device.
Impact in Case of Malfunction	Neutral and grounding lines in the electrical installation do not have access to the device.
Main Associated Error Codes	-
Diagnostics and Test Method	Visual inspection, controlling whether there is burning on contacts and body
Maintenance Requirement	There is no special maintenance requirement.
	

## 4.9. Motorised Valve

Subject	Description
Function of Part	It allows the device to switch between central heating and domestic water.
Impact in Case of Malfunction	There is no switch between central heating and domestic water. The device may overheat. When the domestic water is turned on, central heating may operate, hot water cannot be obtained
Main Associated Error Codes	E03
Diagnostics and Test Method	<ol style="list-style-type: none"> <li>1- Checking that the cables are undamaged and properly mounted on the connector</li> <li>2- Resistance measurement between pins</li> <li>3- Visual inspection of pump position</li> </ol>
Maintenance Requirement	There is no special maintenance requirement.
	

Test definition	Test Method
Voltage and Position Control in Central Heating	While the device is connected to the power, the motorised valve cable is removed and the device is put into central heating mode. Resistance between terminals no. 1-2 is measured. The value must be between 210-240 VAC. The pin must be in the down position when the power is off and the domestic water is turned on by installing a motorised valve.



Voltage and Position Control in Domestic Water Heating	While the device is connected to the power, the motorised valve cable is removed and one of the taps connected to the hot water installation is turned on, and the device is put into domestic water heating mode. Resistance between terminals no. 2-3 is measured. The value must be between 210-240 VAC. The pin must be in the up position when the power is off and the domestic water is turned on by installing a motorised valve.
--	---



## 4.10. Plate Exchanger

Subject	Description
Function of Part	It enables the water heated in the main exchanger to transfer heat to the domestic water during domestic water heating.
Impact in Case of Malfunction	The domestic water and the central heating water may mix. The water pressure in the installation may drop. Dirty water may come from the domestic water.
Main Associated Error Codes	E03, E80, F37
Diagnostics and Test Method	1- Visually inspect the plate exchanger for water leakage. 2- Check whether there is a drop in the water pressure in the installation when the domestic water is turned on.
Maintenance Requirement	Interior cleaning of plate during annual routine maintenance



Maintenance Definition	Maintenance Method
Interior cleaning of plate	1- The plate exchanger is removed. 2- Descaling agent (HN03) is filled into the plate exchanger and waited for 10 minutes. 3- The descaling agent is drained and the inside of the plate exchanger is washed with water.

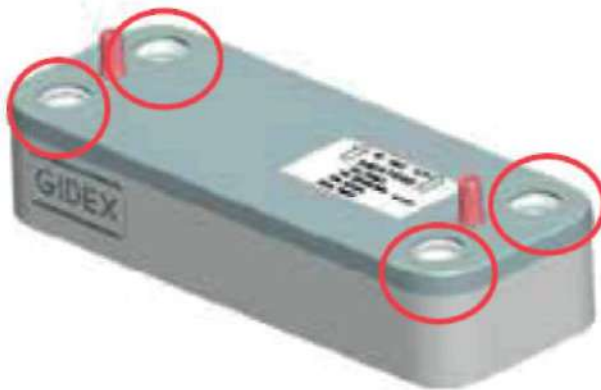





## 4.11. Contactor

Subject	Description
Function of Part	It ensures the continuity of the power circuit by transmitting the energy coming from the Circuit Breaker output contacts of the device to the relays. It protects the device and the installation by turning on the power circuit in fault situations where the heating must be turned off.
Impact in Case of Malfunction	It may not ensure that the device is protected in an emergency, the heating circuit may not be activated, it may cause mainboard damage, or cause the machine to give error by providing incorrect feedback signal.
Main Associated Error Codes	E03, E04
Diagnostics and Test Method	1- Checking the cable connections 2- NO auxiliary contact control 3- Main contact conduction control 4- Coil resistance measurement 5- Visual inspection
Maintenance Requirement	There is no special maintenance requirement.



Test definition	Test Method
Cable Connection Control	Make sure that the cable connections are in accordance with the user manual and that the cables are undamaged. Make sure that the cable connections, especially on the main output contacts, are solid.
NO Auxiliary Contact Control	Turn off power supply of the device. Next, measure the resistance between contacts no. 13 and 14. An open-circuit or a resistance value above 100k should be seen. Then turn on the energy supply and put the device into heating mode. In this case, measure the voltage between the contacts no. 13 and 14 and the neutral terminal and make sure that you see a voltage between 210-240 VAC.



Main Contact Conduction Control	While the contactor is unplugged, check whether there is energy at the contact outputs no. 2, 4 and 6. Each of the contacts must have energy. Then switch the device to "OFF" mode with K1, deactivate the contactor and take the same measurement. None of the contacts must have energy. If these conditions are not met, the contactor is broken and must be replaced.
	
Coil Resistance Measurement	If the short-circuit value is read when the power of device is turned off and the resistance is measured between the terminals A1 and A2 of the contactor, the contactor must be replaced. Under normal conditions, a value above 400Ω should be displayed. The short-circuit in the coil terminals may cause the glass Circuit Breaker of the mainboard to blow and deform the mainboard circuit.
	
Visual inspection	If there is deformation like burning in the contacts of the contactor, replace it together with the damaged cables.

## 4.12. Expansion Tank

Subject	Description
Function of Part	It ensures that the system pressure does not increase in case the water in the closed-circuit water installation expands by heating.
Impact in Case of Malfunction	-
Main Associated Error Codes	F40
Diagnostics and Test Method	Expansion tank gas pressure measure
Maintenance Requirement	There is no special maintenance requirement.



Test definition	Test Method
Expansion Tank Gas Pressure Measure	The water in the central heating installation is drained. Then, the gas pressure is measured from the expansion tank valve with a manometer. The measured value must be higher than 0.5 bar. Otherwise, gas must be added until the pressure rises to 1 bar. (If there is a pressure drop in the expansion tank to which gas is added, within 6 months, the expansion tank must be replaced.)



## 4.13. Overheat thermostat



Subject	Description
Function of Part	It provides protection by shutting off the contact in case of overheating in the main exchanger.
Impact in Case of Malfunction	1. Although there is overheating on the upper surface of the heat exchanger, it may not turn on the contact and protect it. 2. It may prevent the device from heating by incorrectly shutting off the contact, although there is no overheating on the upper surface of the exchanger.
Main Associated Error Codes	E03
Diagnostics and Test Method	-
Maintenance Requirement	There is no special maintenance requirement.



Test definition	Test Method
Resistance measurement between contacts	When the surface it contacts is cold, a measurement is taken between the terminals of the overheat thermostat. If the measurement result is not a short-circuit, it must be replaced.



## 4.14. Surface Type NTC

Subject	Description
Function of Part	It ensures that the device works in accordance with its function, by measuring the central heating supply and return water temperatures.
Impact in Case of Malfunction	It causes the central heating not to work properly, not to heat up or to overheat more than the set temperature.
Main Associated Error Codes	F33, F35, E80
Diagnostics and Test Method	The part may be tested by measuring the resistance between the
Maintenance Requirement	There is no special maintenance requirement.
	
Test definition	Test Method
NTC Resistance Measurement	NTC electrical connections are disconnected and removed. The resistance between the terminals is measured and it is checked whether it provides the appropriate resistance value suitable ambient temperature according to the table. If the resistance value does not comply with the table, the part is replaced.
	
Ambient temperature (°C)	Resistance between NTC terminals (kΩ)
0-5	27.3-22.1
6-10	21.2-18
11-15	17.3 - 14.7
16-20	14.1-12.1
21-25	11.6-10
26-30	9.63 - 8.3
31-35	8 - 6.95
36-40	6.7 - 5.8

## 4.15. Submersion Type NTC

Subject	Description
Function of Part	It is the element that measures the temperature of the water taken from the domestic water outlet.
Impact in Case of Malfunction	1- The desired set temperature cannot be achieved and user comfort is disturbed. 2- The device will not work.
Main Associated Error Codes	F52
Diagnostics and Test Method	The part may be tested by measuring the resistance between the NTC terminals.
Maintenance Requirement	There is no special maintenance requirement.



Test definition	Test Method
NTC Resistance Measurement	NTC electrical connections are disconnected and removed. The resistance between the terminals is measured and it is checked whether it provides the appropriate resistance value suitable ambient temperature according to the table. If the resistance value does not comply with the table, the part is replaced.
<b>Ambient temperature (°C)</b>	<b>Resistance between NTC terminals (kΩ)</b>
0-5	27.3-22.1
6-10	21.2-18
11-15	17.3-14.7
16-20	14.1-12.1
21-25	11.6-10
26-30	9.63-8.3
31-35	8-6.95
36-40	6.7-5.8

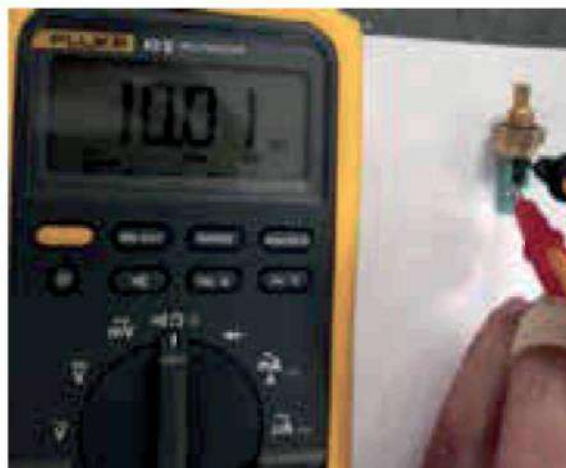



## 4.16. Flow Sensor

Subject	Description
Function of Part	It is the element that detects the request when the flow starts in the domestic water installation.
Impact in Case of Malfunction	1- The domestic water request cannot be detected and heating does not occur. 2- The device will not work.
Main Associated Error Codes	-
Diagnostics and Test Method	1- Checking that the cable connections are undamaged 2- Checking whether there is any oxidation, etc. effect in the flow sensor cable inlet area 3- Voltage test 4- Filter cleaning and control of flow turbine group Note: If the P00 parameter is "5", the device will only work in central heating, so it will not work in domestic water.
Maintenance Requirement	There is no special maintenance requirement.

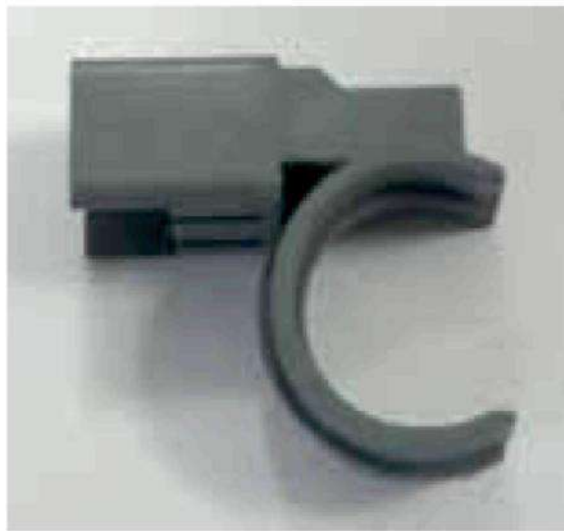

Test definition	Test Method
Flow sensor voltage test	Turn on the domestic water when the device is powered on. The electrical connector on the flow sensor is removed and DC voltage between the "IN"- "GND" terminals shown below is measured. It is checked that the voltage is in the range of 11.5-12.5 VDC.



## 4.17. Air Purger

Subject	Description
Function of Part	It allows the air remained in the installation circuit to be discharged.
Impact in Case of Malfunction	In case of faulty operation, it discharges water instead of air. It causes the water pressure in the installation to drop.
Main Associated Error Codes	F37
Diagnostics and Test Method	Checking whether there is water discharge from the purge.
Maintenance Requirement	There is no special maintenance requirement.





## 4.18. Water Pressure Sensor

Subject	Description
Function of Part	It prevents dry combustion in the device by measuring the water pressure in the installation.
Impact in Case of Malfunction	1- Device gives low or high pressure error. 2- A value different from the actual water pressure is displayed on the user screen. 3- Even if the user fills the installation with water, they may not see the pressure rise.
Main Associated Error Codes	F37, F40, F47
Diagnostics and Test Method	1- Checking that the cable connections are solid and undamaged 2- Checking whether the water inlet hole of the water pressure sensor is clogged 3- Voltage test
Maintenance Requirement	There is no special maintenance requirement.



Test definition	Test Method
Water Pressure Sensor	When the device is powered on, the electrical connector on the water pressure sensor is removed and DC voltage between the "IN"- "GND" terminals shown below is measured. It is checked that the voltage is in the range of 4.9-5.1.

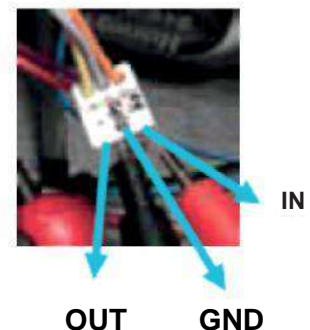

## 4.19. Flow Turbine

<b>Subject</b>	<b>Description</b>
Function of Part	When there is a domestic water request, the turbine structure it has starts to turn and creates the magnetic field that the flow sensor will detect.
Impact in Case of Malfunction	The device cannot detect the domestic water request, it continues to make central heating even if there is a domestic water request.
Main Associated Error Codes	-
Diagnostics and Test Method	1- Checking the flow turbine blades for deformation, splits, cracks, etc. 2- Filter cleaning and control of flow sensor Note: If the P00 parameter is "5", the device will only work in central heating, so it will not work in domestic water.
Maintenance Requirement	There is no special maintenance requirement.

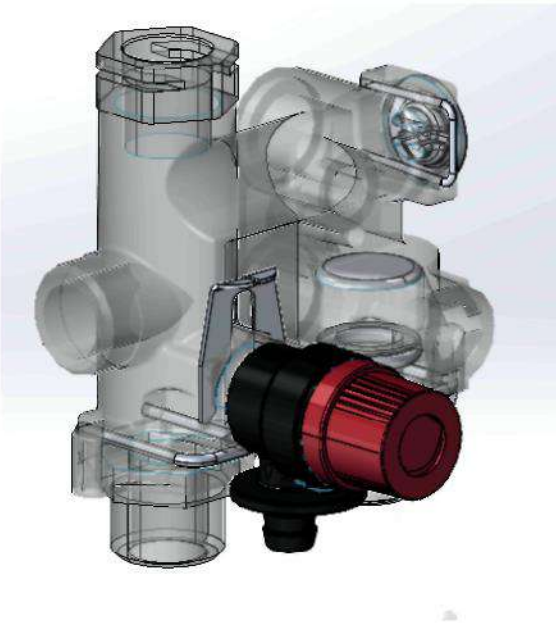

### 4.20. 3 Bar Safety Valve

Subject	Description
Function of Part	It reduces the pressure in the installation by discharging the water at the installation water pressure above 3±0.3 bar.
Impact in Case of Malfunction	1- It may leak water at low pressures, causing the installation pressure to drop. 2- It may cause damage to the hydraulic components of the device by discharging at high pressure.
Main Associated Error Codes	F37, F40
Diagnostics and Test Method	1- Checking whether the valve leaks water when the water pressure in the central heating circuit is between 0.8 - 2.5 bar 2- Opening pressure test
Maintenance Requirement	There is no special maintenance requirement.
	
Test definition	Test Method
Safety Valve Opening-Closing Pressure Test	The central heating system is filled with water by opening the filling tap. The safety valve should open its discharge due to high water pressure in the range of 2.7-3.3 bar and continue to discharge until the water pressure drops to the range of 2.5-2.7 bar.